

LOGIC MAX COMBI²

24 30 35kW



Low lift weight



Intelligent pre-heat



Large colour screen and simple user interface



Ideal System Filter included to maintain and protect your heating system



Compact cupboard fit



Compression fitting included



Enhance boiler performance with Halo

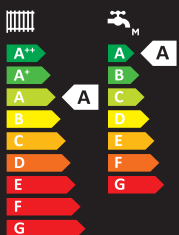
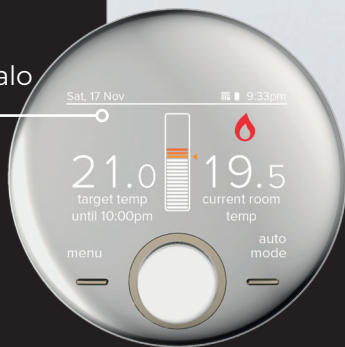

Features & specification

END USER BENEFITS

- Award winning range
- Service indication
- Intelligent pre-heat function
- Large colour screen and simple user interface
- Enhance boiler performance by fitting a Halo thermostat, minimising energy consumption
- LPG conversion kit available for all kW outputs
- Green coloured filling loop handle drives user self-management
- Compatible with green heating technologies including solar thermal and hybrid systems

EASY TO INSTALL

- Honeywell gas valve
- Ideal System Filter included in the box
- Fully labelled and compartmentalised hardware pack
- Wiring centre can accommodate a variety of cable thickness's including 5-core cable with simple screw bridge clamps for fixation
- Designed, developed and made in the UK
- 10 year warranty as standard

- Compact cupboard fit
- Stand-off kit options with and without pipes
- Wide range of flueing options
- Preformed copper tails
- Pre-wired mains lead
- Safety valve outlet pipe included
- Built in filling loop
- Fixed flue turret seal to prevent dislodgement during fitting
- Compression fitting included in the hardware pack
- QR codes linked to 'how to' videos in the instruction manual

EASY TO SERVICE AND MAINTAIN

- Single dual-purpose spark and detection electrode
- Fully serviceable from the front

Clearances & dimensions

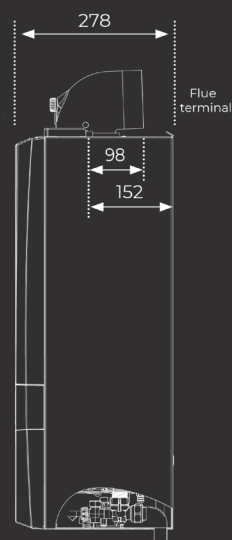
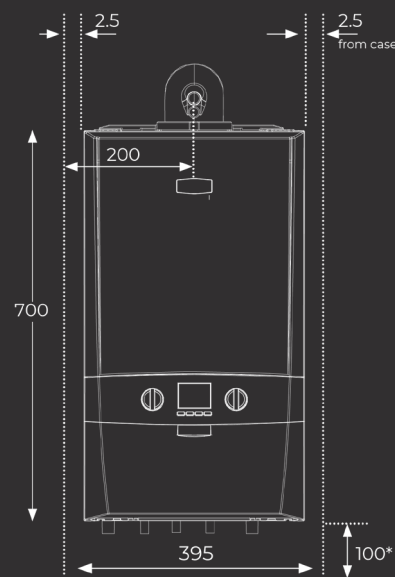

Dimensions in mm.

Technical specification

LOGIC MAX COMBI ² MODELS	24	30	35
Weight(Packaged) kg	32.8	33	33
Max Installation weight kg	28.5	28.6	28.6
CH Output(kW) min /max mean 70°C	4.8-24.2	6.1-24.2	7.1-24.2
CH Output(kW) min /max mean 40°C	5.1-25.6	6.4-25.6	7.5-25.6
DHW output (kW) max	24.2	30.3	35.3
DHW flow rate l/min 35°C	9.9	12.4	14.5
SEDBUK rating (2005)%	91.1	91.1	91.1
SEDBUK rating (2009/2012)%	89.6	89.6	89.6
NOx Classification	Class 6	Class 6	Class 6
LPG conversion	Yes	Yes	Yes
Max Horizontal flue	9m	8m	6m
Max Vertical Flue	7.7m	7.5m	7.5m
Seasonal space heating efficiency class	A	A	A
Seasonal space heating energy efficiency μ s %	94	94	94
Sound power level indoors LWA dB(A)	50	46	46
Water heating energy efficiency class	A	A	A

T: 01482 492251 E: ideal@idealheating.com

Ideal Heating, PO Box 103, National Avenue, Kingston upon Hull, East Yorkshire, HU5 4JN.

Clearances & dimensions notes: **The minimum front clearance when built into a cupboard is 5mm from the cupboard door but 450mm overall clearance with the cupboard door open is required for servicing. *Bottom clearance after installation can be reduced to 5mm. However, 100mm is required for servicing.

